

Omniplate 1500 is an economical barrier wall system with visible caulk joints at all horizontal and vertical panel joints. As a barrier wall, Omniplate 1500 serves as the primary weather barrier for the building envelope. It can be installed on vertical, sloped or horizontal surfaces over masonry, structural steel, stud backup or within curtain wall designs.

Manufactured from either aluminum or stainless steel plate, Omniplate 1500 provides outstanding freedom of form including curves and complex 3D profiles, and permits challenging transitions without exposed trim or joints.

The system installs with concealed fasteners over studs and continuous sheathing, continuous masonry, or concrete. In addition to walls, the system is suited for vestibules, canopies and eyebrows, as well as for enclosing exposed columns, beams, and pilasters.



DETAILS

- Manufactured from solid aluminum or stainless plate with integral panel returns formed from a single piece of metal
- Consult with Metalwërks for zinc plate options
- Solid aluminum and stainless steel: high resistance to denting and puncturing, perfect for high-traffic or abusive environments
- Fully mitered and welded corners ground smooth for seamless appearance
- Panel to panel joints created with backer rod and sealant and at panel perimeters to create a complete airtight and watertight exterior barrier including roofs or sloping projected surfaces
- Non-Combustible: minimal smoke or fuel contribution
- Avoids NFPA 285 complications by avoiding thermo-plastic cores
- All panel systems are reinforced/stiffened to resist deflection limits
- 0.625" (15.88 mm) wide standard horizontal and vertical joint
- Panels install both horizontally and vertically
- Panels attach with concealed corrosion-resistant self-tapping screws
- Aluminum: post-applied finishing for long-term performance and uniform aesthetic
- 100% recyclable with high percentage of post-consumer and industrial content, which may contribute to LEED credits

DESIGN OPTIONS

- Panels may be flat, curved, or custom 3D profiles
- Variable reveals: Horizontal 0.5" - 1" (12.7 mm - 25.4 mm); Vertical 0.5" - 1" (12.7 mm - 25.4 mm)
- Unlimited color options for aluminum plate
- Options for #4, #6, #8, and non-directional finishes for stainless plate
- Matching perforated and louvered panels
- Available shop-applied appliqués for accents
- **Optional back-cuts on formed panel edges for a sharper bend and crisper appearance**
- Integrated Copings
- Also compatible as column and beam cladding, canopy cladding, and custom 3D enclosures

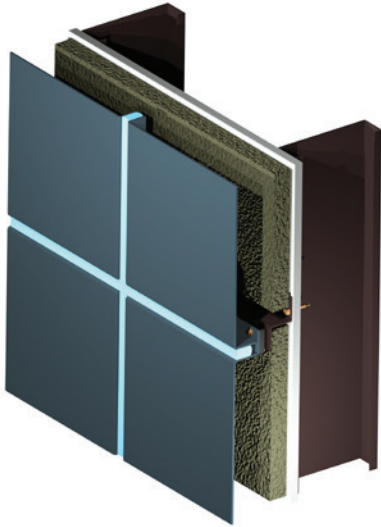

HORIZONTAL JOINT

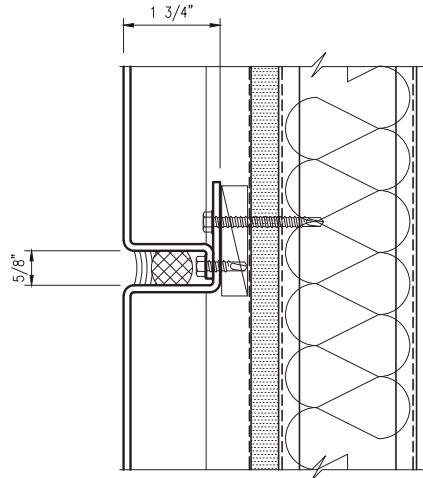

VERTICAL JOINT

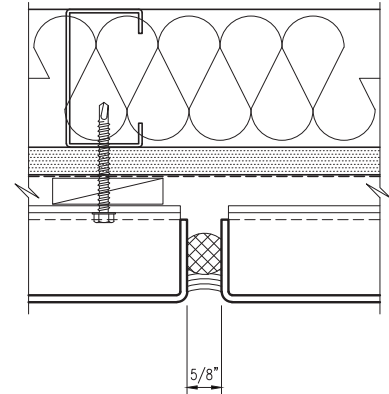

METAL SUBSTRATE AND FINISH OPTIONS

ALUMINUM

3003-H14 aluminum alloy-temper

Thickness: 0.125" (3.18 mm) standard, 0.090" (2.29 mm), 0.188" (4.78 mm), 0.25" (6.35 mm) options

Finishes: Kynar®, architectural TGIC Polyester powder coating, or anodized

STAINLESS STEEL

T304 or T316

Thickness: 14 gauge (0.078") (1.98 mm) standard, 16 gauge (0.063") (1.60 mm), 12 gauge (0.109") (2.78 mm) options

Finishes: #4, #6, #8, and non-directional satin in smooth or custom embossed patterns

PANEL SIZES

Widths: 12" (305 mm) to 65" (1,651 mm)*

Lengths: 12" (305 mm) to 160" (4,064 mm)*

Depth: 1.75" (44.45 mm) minimum

* Maximum panel size depends upon plate material, gauge, finish, and geometry

PANEL WEIGHT RANGE

(dependent upon gauge and geometry)

Aluminum: 2.22 - 4.02 lbs./ft²

Stainless Steel: 4.64 - 5.913 lbs./ft²

Zinc: Consult with Metalwërks

Ranges provided for clarification. Consult with Metalwërks for further options.

SHARP CORNER

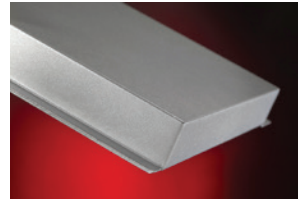

STANDARD CORNER

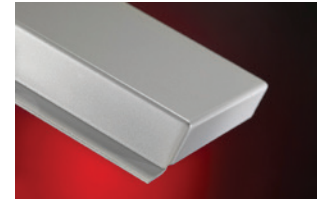

ACCESSORIES

Flashing: Formed sheet metal flashing which may be required at base or penetration conditions produced in the same material finish as the panel system

Coping: May be produced with the same material as the wall panel system

Furring Channels: As required for proper mounting of panels in 16 gauge minimum thickness

Fasteners: Type 304 Stainless Steel or Cadmium plated as recommended for specific application

Shims: High impact thermally-broken plastic shims to maintain co-planar surfaces

TESTING

Air Infiltration: When tested in accordance with ASTM E 283-04

Water Infiltration: No water infiltration shall occur when tested in accordance with ASTM E 331-00 and AAMA 501.1-05 (Static and Dynamic Pressure Water Resistance)

Structural: When tested in accordance with ASTM E330-02

ASTM B 209: *Standard Specification for Aluminum and Aluminum-Alloy Sheet and Steel*

AAMA 2605.2: *Voluntary Specification for High Performance Organic Coatings on Architectural Aluminum Extrusions and Panel*

WARRANTY

Material & Workmanship: 1-year standard, with 2- or 5-year options

Finish Integrity: 10-year standard and up to 20-year for coated aluminum